

**Planning of the navigable connection between the Blunoer South Lake – Partwitzer Lake  
Connecting Canal 7**

C&E · Consulting und Engineering GmbH



09117 Chemnitz • Jagdschänkenstraße 52  
Tel.: +49 (0) 371 881 22 39 • Fax: +49 (0) 371 881 45 89  
E-mail: info@cue-chemnitz.de  
Internet: www.cue-chemnitz.de

**Project Objective:** Navigable connection between the Blunoer South Lake and Partwitzer Lake

**Location:** Municipality Elsterheide / Saxony

**Client:** LMBV

**Beneficiary:** LMBV,

**Year:** 2005-2006

**Investment:** 3.954.000 €

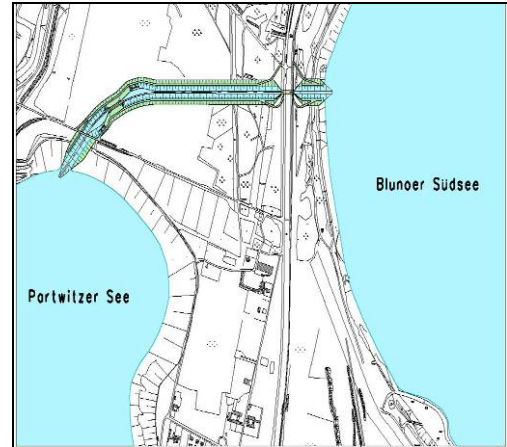

**Services Provided:**

Phases

- Basic investigation
- Preliminary planning

Including

- Navigable canal
  - Total length approx. 965 m
  - Standard width: 6,0 m
  - Inclination of slope 1:3
  - Water depth: 2,5 ... 3,25 m
- Watergate incl. offshore terminals
  - Total length of watergate construction: 44,10 m
  - Total length of watergate chamber: 27,46 m
  - Length of the chamber which can be used: 24,0 m
  - Clear width of chamber: 6,0 m
  - Length of offshore terminals: each 95,0 m
- Tunnel construction
  - Clear width of profile: 7,50 m
  - Clear height of profile: 7,25 m
- Bridge construction
  - Span width: 43,7 m
  - Roadway width incl. emergency sidewalks: 3,5 m

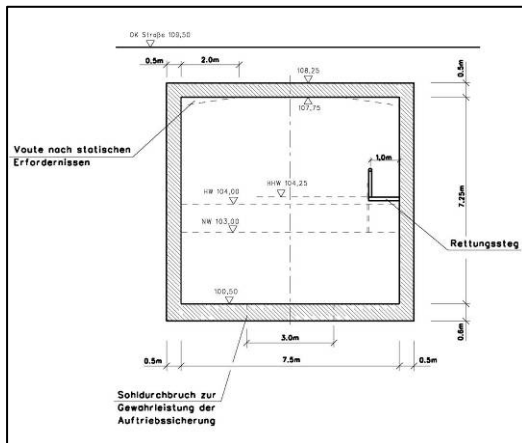
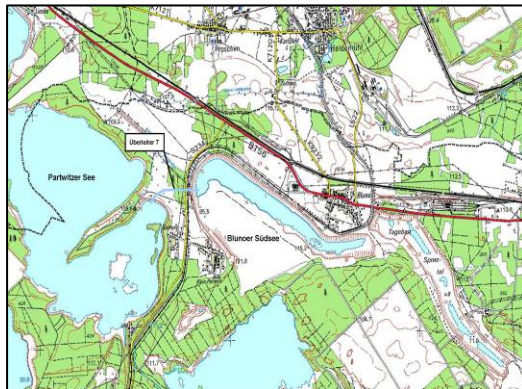

**Planning of the navigable connection between the Blunzer South Lake – Partwitzer Lake Connecting Canal 7**

C&E · Consulting und Engineering GmbH



09117 Chemnitz • Jagdschänkenstraße 52  
Tel.: +49 (0) 371 881 22 39 • Fax: +49 (0) 371 881 45 89  
E-mail: info@cue-chemnitz.de  
Internet: www.cue-chemnitz.de

